



DESCRIPTION

The 1400 High Efficiency Series DC/DC Converter applies advanced technology and is configured specifically for electric vehicles. Available in 250W and 375W models, the devices provide a precise regulated output of 12.0 or 24.0 volts for computer terminals and communication equipment. Provides 13.5 or 28.0 volts for driving lamps and charging auxiliary batteries.

APPLICATION

Designed to provide a reduced voltage supply to power auxiliary electrical systems, the Curtis 1400 Series High Efficiency DC/DC Converters achieve unmatched levels of efficiency and safety.

FEATURES

- Maximum pulse power exceeds 125% of the nominal rating.
- Simple to install, compact and versatile—can be mounted in any position.
- Safe to use, di-electrically isolated output, thermal protection, transient protection, reverse polarity protection.
- Provides power to auxiliary electrical circuits on an electrical vehicle without recourse to battery tapping which is unsafe, damaging to the battery and may contravene EC regulations.
- Regulated outputs preclude lights from dimming and other effects of voltage drop caused by battery loading.
- Input and output are di-electrically isolated for maximum safety.
- Over 85% efficient with high power density.
- The output is regulated to $\pm 1.5\%$. Model 1400 Series is superior to previously available converters and prevents battery damage and unsafe installations caused by battery tappings.
- Due to superior efficiency less heat is generated which, together with transient protection, leads to improved reliability.
- Smaller, lighter and significantly more quiet than conventional converters.

OPTIONS

- Available in both 250 Watt peak and 375 Watt peak models.
- Range of models to cover 24 to 96 volt input with 12.0, 13.5, 24.0 or 28.0 volt output.

1400 SERIES

DIMENSIONS MM (IN)

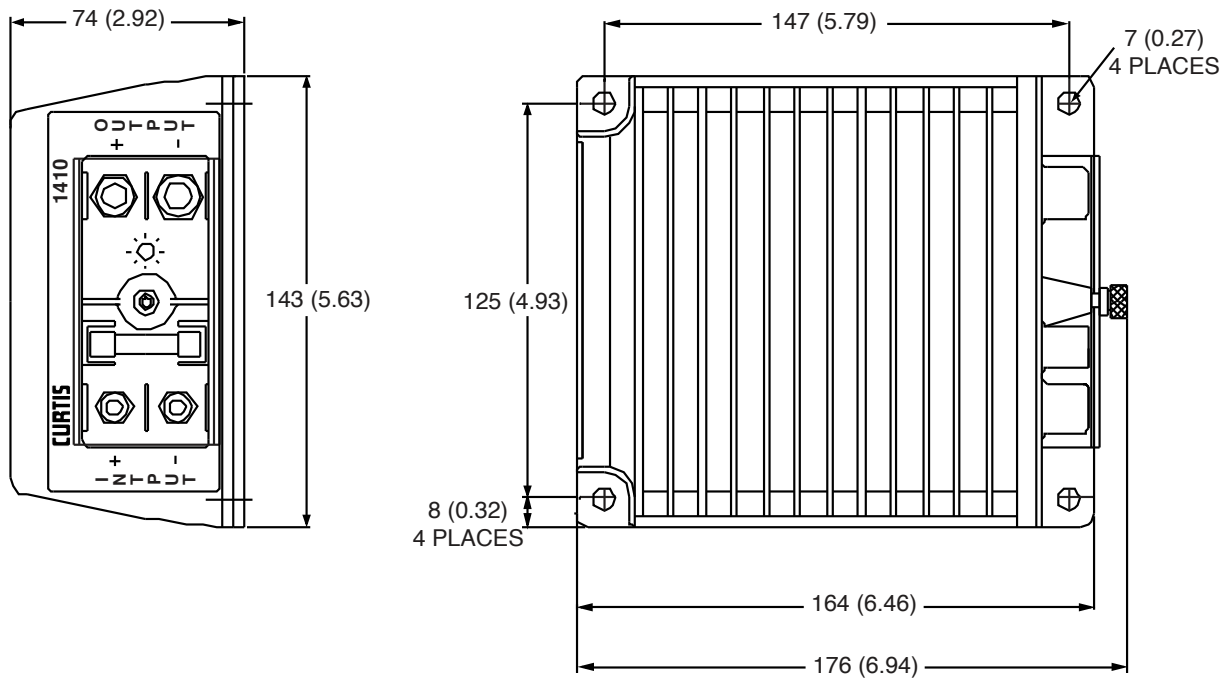

Terminal Torque Settings

M5: 4.5 Nm ± 0.5

M6: 6.8 Nm ± 0.5

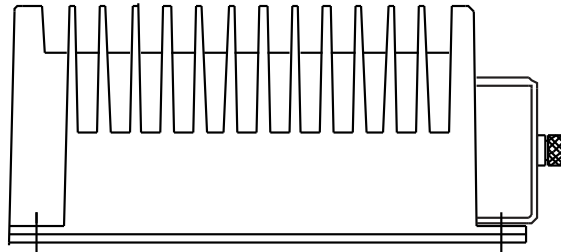

AVAILABLE MODELS

MODEL	1400E	1410E	1400E	1410E
	OUTPUT VOLTAGE		NOMINAL OUTPUT CURRENT LIMIT	
1201	13.5 VDC	13.5 VDC	22.2A	14.8A
1203	12.0 VDC	12.0 VDC	25.0A	16.7A
2401	28.0 VDC	28.0 VDC	10.7A	7.1A
2403	24.0 VDC	24.0 VDC	12.5A	8.4A

WARRANTY Two Year Limited Warranty from time of delivery.

